

79" Impress Fabric Display

SINGLE SIDED KIT: 254203
DOUBLE SIDED KIT: 254204

Product Parts

- 1-Foot (x2)
- 2-Corner Piece (x4)
- 3-Connector (x4)
- 4-Extrusion Bar with Connector End (x4)
- 5-Extrusion Bar without Connector End (x4)
- 6. Fabric Graphic (x1-for single sided)
(x2-for double sided)

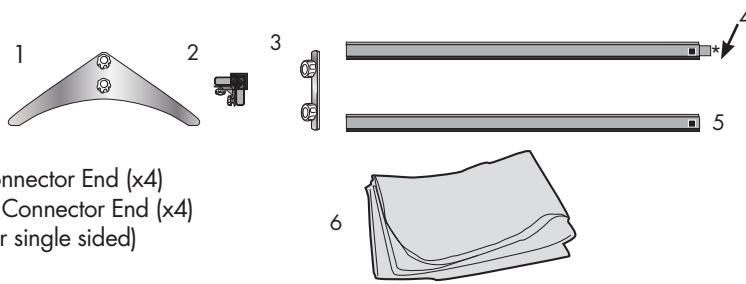

Display Set up

Step 1 (Overview of Frame Pieces)

Remove all of the product parts from the bag and place, on a clean flat surface. Take the time to review the pattern layout and notice that all pieces have one of the following symbols along with a number:



FOOT



RIGHT ANGLE



STRAIGHT

Make sure all labels are visible before you put your frame together. ALL LABELS MUST BE VISIBLE for frame to be assembled correctly.

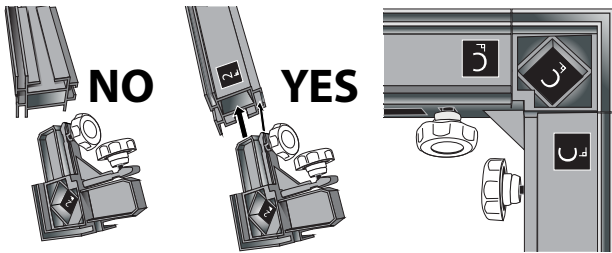

All Extrusion Bars (4) are connected using Straight Connectors (3)

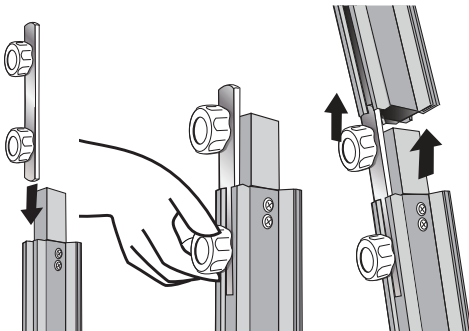

PATTERN LAYOUT:

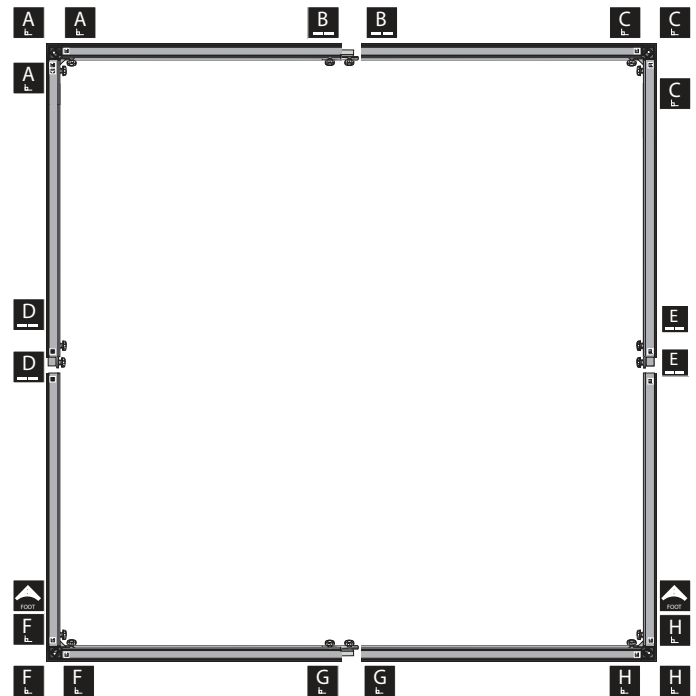

Display Set-Up

Step 2

Place the Foot (1) piece onto its corresponding Extrusion Bar BEFORE attaching bottom Corner Pieces (2). Make sure to slide the Foot (1) up enough on the bar to attach the Corner Piece (2)

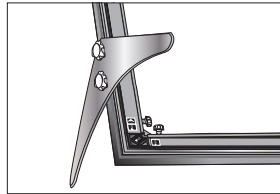
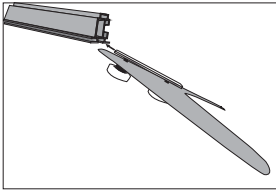

Step 3 Once the frame is all together set display upright. Lower the feet and tighten in place by turning both knobs.

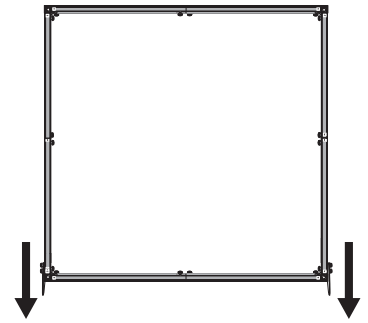
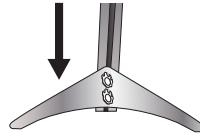

FRAME IS NOW READY FOR FABRIC GRAPHIC (6).

Step 4

With feet in place and tightened, lay Frame back down on the floor. Start by installing Fabric Graphic (6) into each corner.

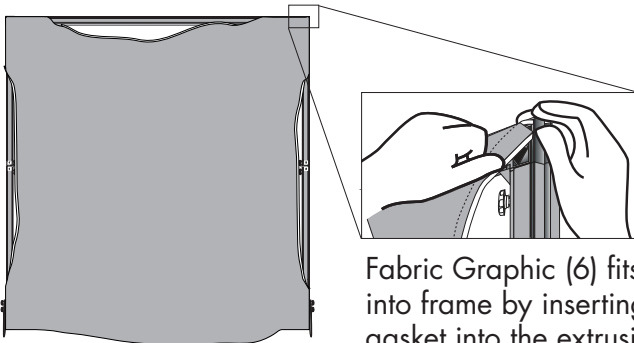

Fabric Graphic (6) fits into frame by inserting gasket into the extrusion channel.

Step 5

Once each corner is secure, work toward center on each side, using thumb to smooth gasket.

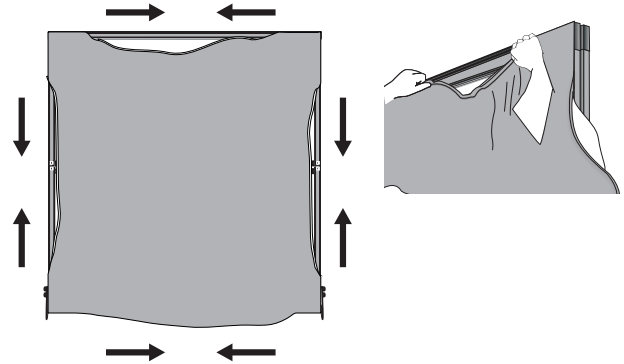

Step 6

Set display back upright and smooth out Fabric Graphic (6) as needed.

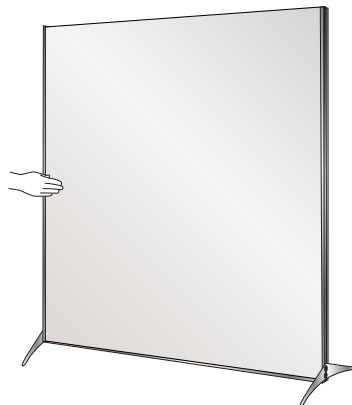

Storage and Care

Place all product parts into Carry Case and store in a cool dry location.

To clean, wipe with damp cloth.